

INSTALLATION INSTRUCTIONS

1. Attach the disk to the collar on the motor shaft with the screws provided.
2. Mount the unit to your tank top (hardware is not provided).
3. Place a bucket under the discharge trough.
4. Plug the unit into a proper outlet and let it work.

MOTOR SPECIFICATIONS

- Fan-cooled motors rated at 10,000 hours MTBF
- Non drip-proof motor
- This unit needs to be operated just a few hours per day under normal conditions

WARNINGS

- Do not immerse motor in any liquid
- Shield motor from spray and vapor
- Do not use in explosive atmosphere
- Per NEC regulations, a ground fault interrupt must be installed
- If the disk stops picking up oil, the oil layer has become a biofilm. Contact Zebra® Skimmers for more info.

WARRANTY

- Disks are warranted for 90 days and wipers for lifetime (one set per year), Replacement wipers can be requested by contacting us. (Disk and wipers can also be purchased as spares for other units).
- Product/parts are warranted for 90 days

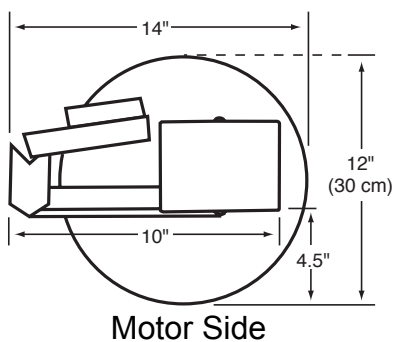
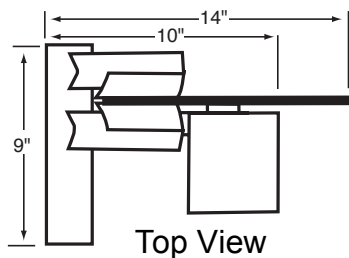

For any technical questions or product support, please contact us at 440.528.0699

AVAILABLE REPLACEMENT PARTS

REPLACEMENT DISKS

DISK-A300	Acrylic Disk, 12" dia., 3/16" thick
DISK-H300	High-Impact Disk, 12" dia, 1/4" thick
DISK-W300	High-Temp Disk, 12" dia, 1/2" thick

LXWIP	Wiper Set for disk skimmers, 2 per set
-------	--

REPLACEMENT MOTORS

MG02A1	Motor, 115v, 2rpm, Assembly w/fan
MG02A2	Motor, 115v, 2rpm, RAW w/fan
MG07A1	Motor, 115v, 7rpm, Assembly w/fan
MG07A2	Motor, 115v, 7rpm, RAW w/fan



Zebra Skimmers Corporation

27000 Richmond Road #1 | Solon, OH 44139 | Toll Free: 888.249.4855 | Fax: 440-349-1211
 sales@zebraskimmers.com | www.zebraskimmers.com