



# Operating Instructions and Parts Manual

## 8-inch Variable Speed Bench Grinder

Model IBG-8VS



**JET**  
427 New Sanford Road  
LaVergne, Tennessee 37086  
Ph.: 800-274-6848  
www.jettools.com

**Part No. M-578208**  
Edition 4 03/2019  
Copyright © 2017 JET



## 1.0 IMPORTANT SAFETY INSTRUCTIONS

### WARNING – To reduce risk of injury:

1. Read and understand the entire owner's manual before attempting assembly or operation.
2. Read and understand the warnings posted on the machine and in this manual. Failure to comply with all of these warnings may cause serious injury.
3. Replace warning labels if they become obscured or removed.
4. This bench grinder is designed and intended for use by properly trained and experienced personnel only. If you are not familiar with the proper and safe operation of a bench grinder, do not use until proper training and knowledge have been obtained.
5. Do not use this bench grinder for other than its intended use. If used for other purposes, JET disclaims any real or implied warranty and holds itself harmless from any injury that may result from that use.
6. Always wear protective eye wear when operating machinery. Eye wear shall be impact resistant, protective safety glasses with side shields which comply with ANSI Z87.1 specifications. Use of eye wear which does not comply with ANSI Z87.1 specifications could result in severe injury from breakage of eye protection. (Everyday eyeglasses only have impact resistant lenses; they are NOT safety glasses.)
7. Use the grinder's eye shields and spark guards. Also use respiratory protection if cutting operation is dusty.
8. Wear proper apparel. Do not wear loose clothing, neckties, rings, bracelets, or other jewelry which may get caught in moving parts. Non-slip footwear is recommended. Wear protective hair covering to contain long hair.
9. Wear protective clothing such as apron or safety shoes, where the grinding activity presents a hazard to the operator.
10. Wear ear protectors (plugs or muffs) if the particular work requires it.
11. Do not operate this machine while tired or under the influence of drugs, alcohol or any medication.
12. Make certain the switch is in the OFF position before connecting the machine to the power supply.
13. Make certain the machine is properly grounded.
14. Make all machine adjustments or maintenance with the machine unplugged from the power source.
15. Remove adjusting keys and wrenches. Form a habit of checking to see that keys and adjusting wrenches are removed from the machine before turning it on.
16. Keep safety guards in place at all times when the machine is in use. If removed for maintenance purposes, use extreme caution and replace the guards immediately after completion of maintenance.
17. Check damaged parts. Before further use of the machine, a guard or other part that is damaged should be carefully checked to determine that it will operate properly and perform its intended function. Check for alignment of moving parts, binding of moving parts, breakage of parts, mounting and any other conditions that may affect its operation. A guard or other part that is damaged should be properly repaired or replaced.
18. Provide for adequate space surrounding work area and non-glare, overhead lighting.
19. Keep the floor around the machine clean and free of scrap material, oil and grease.
20. Keep visitors a safe distance from the work area. Keep children away.
21. Make your workshop child proof with padlocks, master switches or by removing starter keys.
22. Give your work undivided attention. Looking around, carrying on a conversation and "horse-play" are careless acts that can result in serious injury.
23. Keep proper footing and balance at all times so that you do not fall into or lean against the grinding wheel or other moving parts. Do not overreach or use excessive force to perform any machine operation.
24. Disconnect grinder from power source before servicing and when changing abrasive wheels.
25. Use recommended accessories. The use of improper accessories may cause risk of injury to persons.
26. Turn off the machine before cleaning. Use a brush to remove chips or debris — do not use your hands.
27. Never leave the grinder running unattended. Turn power off and do not leave machine until wheels come to a complete stop.
28. Remove loose items and unnecessary work pieces from the area before starting the grinder.
29. Don't use in dangerous environment. Don't use power tools in damp or wet location, or expose them to rain. Don't use this grinder in a flammable environment. Keep work area well lighted.

30. Keep work area clean. Cluttered areas and benches invite accidents.
31. Use the right tool. Don't force tool or attachment to do a job for which it was not designed.
32. Use proper extension cord. Make sure your extension cord is in good condition. When using an extension cord, be sure to use one heavy enough to carry the current your product will draw. An undersized cord will cause a drop in line voltage resulting in loss of power and overheating. Table 1 (see sect. 6.2) shows the correct size to use depending on cord length and nameplate ampere rating. If in doubt, use the next heavier gage. The smaller the gage number, the heavier the cord.
33. Maintain tools with care. Keep tools sharp and clean for best and safest performance. Follow instructions for lubricating and changing accessories.
34. Direction of feed: Feed work into a blade or cutter against the direction of rotation of the blade or cutter only.
35. Do not overtighten wheel nut.
36. Frequently clean grinding dust from beneath grinder.
37. Use grinding wheel suitable for speed of grinder.
38. Inspect abrasive wheels for cracks or other forms of damage. Perform a "ring test" to check wheel integrity. Do not use a faulty or damaged wheel.
39. Verify that maximum RPM of abrasive wheels is compatible with speed of grinder. Do not remove the blotter (label) from either side of a grinding wheel.
40. Allow abrasive wheels to reach full RPM before starting the grinding operation.
41. Do not crowd the work so that the wheels slow.
42. Tool rests should be adjusted to approximately 1/16" from wheel surface.
43. Do not grind on the side of a wheel; do all work on the grinding face or edge near the tool rest.
44. Do not grind aluminum or magnesium, as these may pose a fire hazard.
45. Use only the flanges that are furnished with the grinder.
46. Do not start the grinder while a workpiece is contacting a grinding wheel.

**⚠ WARNING:** This product can expose you to chemicals including lead which is known to the State of California to cause cancer and birth defects or other reproductive harm. For more information go to <http://www.p65warnings.ca.gov>.

**⚠ WARNING:** Some dust, fumes and gases created by power sanding, sawing, grinding, drilling, welding and other construction activities contain chemicals known to the State of California to cause cancer and birth defects or other reproductive harm. Some examples of these chemicals are:

- lead from lead based paint
- crystalline silica from bricks, cement and other masonry products
- arsenic and chromium from chemically treated lumber

Your risk of exposure varies, depending on how often you do this type of work. To reduce your exposure to these chemicals, work in a well-ventilated area and work with approved safety equipment, such as dust masks that are specifically designed to filter out microscopic particles. For more information go to <http://www.p65warnings.ca.gov/> and <http://www.p65warnings.ca.gov/wood>.

## SAVE THESE INSTRUCTIONS

Familiarize yourself with the following safety notices used in this manual:

**⚠ CAUTION** This means that if precautions are not heeded, it may result in minor injury and/or possible machine damage.

**⚠ WARNING** This means that if precautions are not heeded, it may result in serious, or possibly even fatal, injury.

## 2.0 Table of contents

Section	Page
1.0 IMPORTANT SAFETY INSTRUCTIONS .....	2
2.0 Table of contents .....	4
3.0 About this manual .....	5
4.0 Specifications .....	6
4.1 Mounting hole dimensions.....	7
5.0 Setup and assembly.....	8
5.1 Unpacking .....	8
5.2 Carton contents .....	8
5.3 Tools required for assembly .....	8
5.4 Securing the grinder .....	8
5.5 Assembling eye shield brackets to spark guards .....	9
5.6 Installing spark guards/brackets .....	9
5.7 Eye shields .....	9
5.8 Tool rests.....	9
5.9 T-fitting and sleeves .....	9
6.0 Electrical connections .....	10
6.1 Grounding instructions .....	10
6.2 Extension cords.....	10
6.3 Voltage conversion.....	11
7.0 Operation .....	11
7.1 Operating controls .....	11
7.2 Precautions .....	11
8.0 Adjustments .....	12
8.1 Eye shield tilt adjustment.....	12
8.2 Spark guard.....	12
8.3 Tool rest .....	12
9.0 User-maintenance.....	12
9.1 Ring test .....	12
9.2 Care of grinding wheels.....	12
9.3 Changing wheels.....	12
9.4 Wheel balancing.....	13
9.5 Dressing the wheels .....	14
9.6 Wire wheel brushes.....	14
9.7 Cleaning .....	14
9.8 Lubrication.....	14
9.9 Additional servicing .....	14
10.0 Troubleshooting IBG-8VS Bench Grinder .....	15
10.1 General electrical and mechanical problems .....	15
10.2 Digital readout error codes .....	16
11.0 Optional accessories.....	17
12.0 Replacement Parts.....	17
12.1.1 IBG-8VS Variable Speed Grinder – Exploded View.....	18
12.1.2 IBG-8VS Variable Speed Grinder – Parts List.....	19
12.2.1 IBG-Stand Assembly (OPTIONAL) – Exploded View.....	21
12.2.2 IBG-Stand Assembly (OPTIONAL) – Parts List .....	21
12.3.1 DBG-Stand Assembly (OPTIONAL) – Exploded View .....	22
12.3.2 DBG-Stand Assembly (OPTIONAL) – Parts List.....	22
13.0 Electrical Connections – IBG-8VS Grinder .....	23
14.0 Warranty and Service.....	24

## 3.0 About this manual

This manual is provided by JET, covering the safe operation and maintenance procedures for a JET IBG-8VS Variable Speed Bench Grinder. This manual contains instructions on installation, safety precautions, general operating procedures, maintenance instructions and parts breakdown. Your grinder has been designed and constructed to provide consistent, long-term operation if used in accordance with the instructions set forth in this document.

The operator is encouraged to familiarize him/herself with ANSI B7.1 – *Safety Requirements for Use, Care and Protection of Abrasive Wheels*.

If there are questions or comments, please contact your local supplier or JET. JET can also be reached at our web site: [www.jettools.com](http://www.jettools.com).

Retain this manual for future reference. If the grinder transfers ownership, the manual should accompany it.

** **WARNING** Read and understand the entire contents of this manual before attempting assembly or operation! Failure to comply may cause serious injury!**

Register your product using the mail-in card provided, or register online:

<http://www.jettools.com/us/en/service-and-support/warranty/registration/>

## 4.0 Specifications

Model number	<b>IBG-8VS</b>
Stock number	578208
<b>Motor and Electricals</b>	
Motor type	Totally enclosed fan-cooled induction with inverter
Horsepower (true output)	1
Motor phase	3
Voltage	115/230V (prewired 115V)
Input power	<b>single phase</b>
Cycle	60 Hz
Listed FLA (full load amps)	7 / 3.5 A
On/off switch	TACT switch
Motor speed	Variable, 900-3600 RPM
Power cable size	16AWG x 3C SJT, 6 ft. (182 cm)
Power plug installed	5-15P, 125V/15A
Recommended circuit size <sup>1</sup>	15A
Sound emission without load <sup>2</sup>	75 dB at 3 ft.
<b>Arbor and grinding wheels</b>	
Arbor diameter	5/8 in. (16mm)
Wheel size (dia. x width)	8 x 1 in. (16 x 25.4mm)
Wheel bore	5/8 in. (16mm)
Wheel material	aluminum oxide
Wheel grits	36 and 60
Wheel flange diameter	3-3/8 in. (85mm)
Wheel speed	Variable, 900-3600 RPM
Arbor nut maximum tightening torque	20 lbf•ft (270 kgf•cm)
Tool rest distance to wheel	adjustable
<b>Main materials</b>	
Arbor	Steel
Base	Cast iron
Motor housing	Sheet metal
Inner wheel guard	Cast iron
Outer wheel guard	Aluminum
Flange washers	Cast iron
Tool rests	Cast iron
Eye shields	Clear polycarbonate
Spark guards	Steel
Knobs	Polymide
Connector sleeve	ABS
T-fitting	ABS
<b>Dimensions</b>	
Mounting hole centers	8-1/2 in. (215mm)
Mounting hole diameters	7/16 in. (11mm)
Footprint (width x depth)	9-1/2 x 8-1/16 in. (241.6 x 205 mm)
Assembled dimensions (LxWxH)	22-1/2 x 13-3/8 x 13-15/16 in. (572 x 340 x 354 mm)
Shipping dimensions (LxWxH)	22-13/16 x 13-1/2 x 14 in. (580 x 342 x 356 mm)
<b>Dust/swarf collection</b>	
Dust port outside diameter	2-1/2 in. (63.5 mm)
Required min. extraction volume	350 CFM
<b>Weights</b>	
Net weight	66 lb (30.14 kg)
Shipping weight	72 lb (32.55 kg)

<sup>1</sup> subject to local/national electrical codes.

<sup>2</sup> The specified values are emission levels and are not necessarily to be seen as safe operating levels. As workplace conditions vary, this information is intended to allow the user to make a better estimation of the hazards and risks involved only.

L = length, W = width, H = height

n/a = not applicable

The specifications in this manual were current at time of publication, but because of our policy of continuous improvement, JET reserves the right to change specifications at any time and without prior notice, without incurring obligations.

## 4.1 Mounting hole dimensions

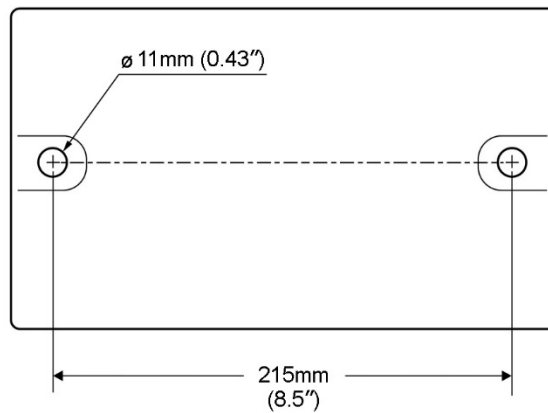

Figure 4-1: IBG-8VS hole centers

## 5.0 Setup and assembly

### 5.1 Unpacking

Separate all parts from the packing material. Check each part against *sect. 5.2, Carton contents*, and make certain that all items are accounted for before discarding any packing material. (Check grinder first to verify if any parts have been pre-mounted.)

### 5.2 Carton contents

Refer to *Figure 5-1*.

- 1 ea Grinder (*not shown*)
- 1 ea Plastic T-fitting (*not shown*)
- 2 ea Plastic connector sleeves (*not shown*)
- 1 ea Spark guard – Left (A)
- 2 ea Lock knob (B)
- 1 ea Spark guard – Right (C)
- 1 ea Eye shield bracket – Left (D)
- 2 ea Flat washer, 1/4" (E)
- 1 ea Eye shield bracket – Right (F)
- 2 ea Eye shield plate (G)
- 4 ea Truss head screw, 3/16 x 1/2" (H)
- 4 ea Hex cap screw, 3/8 x 3/4" (J)
- 4 ea Hex cap screw, 3/8 x 1/2" (K)
- 8 ea Flat washer 3/8" (L)
- 1 ea Tool rest – Left (M)
- 1 ea Tool rest – Right (N)
- 2 ea Eye shield (O)
- 1 ea Wheel dresser (P)

### 5.3 Tools required for assembly

- Cross-point (Phillips) screwdriver
- 14mm (or adjustable) wrench

The IBG-8VS bench grinder requires only the assembly of the eye shields and tool rests. Additional tools may be needed for fastening the grinder to a workbench or stand. For your safety, do not plug the grinder into a power source until all assembly and adjustments are complete.

**⚠WARNING** Be sure that the bench grinder is unplugged and the power switch is in the OFF position. Do not plug in the grinder to power until it is inspected for shipping damage, fully assembled, and moved to its permanent location. Failure to comply may cause serious injury.

**⚠WARNING** Do not operate this grinder without all guards and shields in place and in working order. Failure to comply may cause serious injury.

**⚠WARNING** Chipped or cracked wheels can break up and cause serious damage to the grinder and/or severe injury to the operator. Regularly inspect wheels for damage.

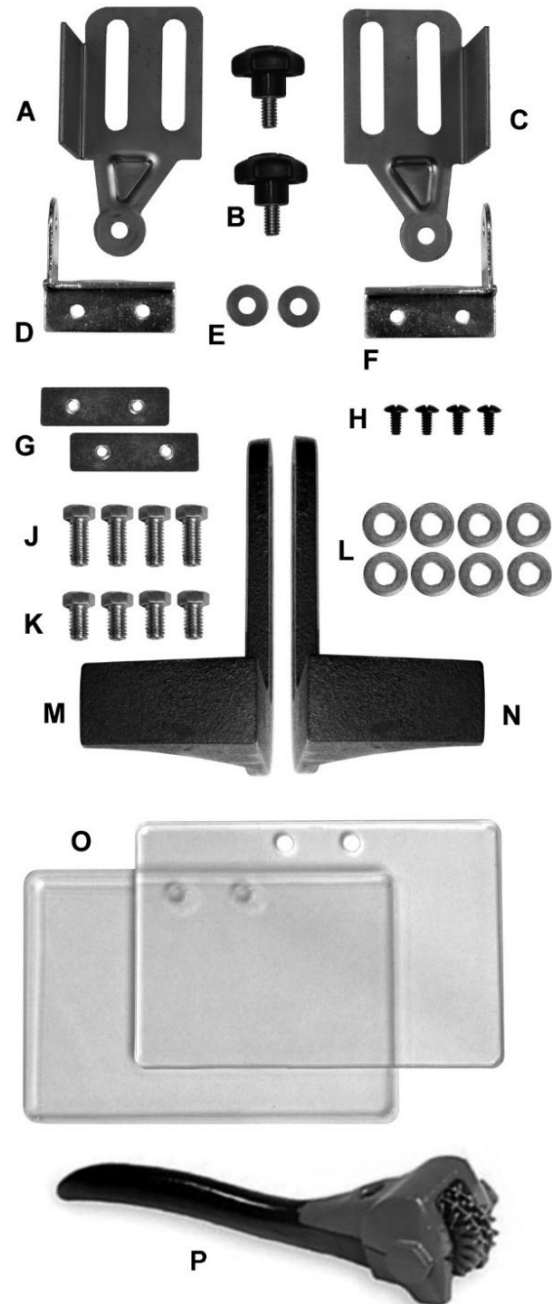

Figure 5-1: Carton contents

### 5.4 Securing the grinder

To prevent the machine from moving during operation, it should be securely mounted to a work surface or grinder stand. Fasteners for mounting are not included with the grinder.

1. Align the mounting holes on the grinder with predrilled holes in a bench or grinder stand. Figure 4-1 shows hole centers for mounting.
2. Insert M8 (or 5/16") bolts through the holes and tighten, using washers and nuts.

An optional pedestal stand (not included) is available from JET for your grinder. See *sect. 11.0*.



**IMPORTANT:** The grinder's base plate contains ventilation holes for keeping the circuit board at an acceptable temperature. These holes should not be obstructed. If the rubber pads are removed for mounting to a table, allow an opening in the table below the grinder for air circulation. However, it is recommended the rubber pads be left on, as they allow air circulation as well as vibration dampening.

## 5.5 Assembling eye shield brackets to spark guards

Refer to Figure 5-2.

**Note:** Spark guards (A) and eye shield brackets (D) are marked **L** for left side assembly and **R** for right side assembly.

1. Assemble the left spark guard and eye shield bracket using Figure 5-2 as a guide. Make sure spark guard and bracket are both marked **L**.
2. Install the right assembly in the same manner.

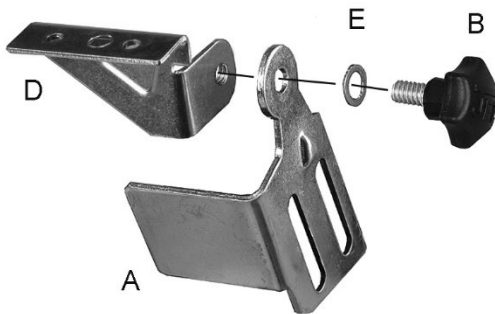

Figure 5-2: brackets to spark guards

## 5.6 Installing spark guards/brackets

Refer to Figure 5-3.

1. Install the left spark guard and mounting bracket assembly to the left wheel housing with two 3/8 x 1/2" hex cap screws (K) and two 3/8" flat washers (L).
2. Install the right spark guard and mounting bracket in the same manner.
3. The spark guards (A<sub>1</sub>) should be adjusted to within 1/16" of the grinding wheel surface or other accessory being used. As the wheel wears down, the spark guards must be re-adjusted to maintain this 1/16" distance.

## 5.7 Eye shields

Refer to Figure 5-3.

The eye shields (O) are identical and will fit on either side of the grinder.

1. Insert two 3/16" x 1/2" truss head screws (H) through the bracket, eye shield (O), and plate (G) which contains threaded mounting holes.
2. Tighten the screws (H).

## 5.8 Tool rests

Refer to Figure 5-3.

**Note:** There is a *left* and a *right* tool rest. Refer to Figure 5-3 for proper orientation.

1. Install the left tool rest (M) by inserting two 3/8" x 3/4" hex cap screws (J) through two 3/8" flat washers (L), through the tool rest (M), into the wheel housing.
2. Install the right tool rest in the same manner.
3. The tool rests should be adjusted to within 1/16" of the grinding wheel or other accessories being used. As the wheel wears down, the tool rest must be readjusted to maintain a 1/16" clearance.

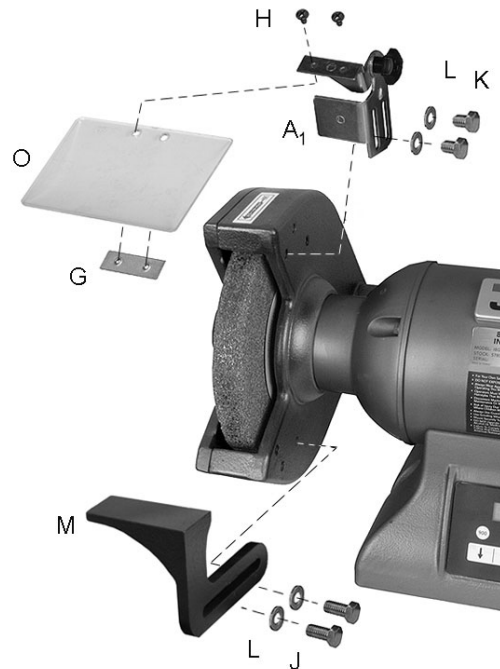

Figure 5-3: guards and tool rests

## 5.9 T-fitting and sleeves

Refer to Figure 5-4.

Assemble the connector sleeves to the T-fitting, and attach the sleeve ends to the dust ports of the wheel guards, as shown. The T-connector has a 2-1/2" outside diameter port for attaching a dust collection system.



Figure 5-4: dust extraction

## 6.0 Electrical connections

**⚠WARNING** Electrical connections should be made by a qualified electrician in compliance with all relevant codes. This tool must be properly grounded.

The **IBG-8VS** Grinder is prewired for 115V single phase power, and is supplied with a plug designed for use on a circuit with a grounded outlet that looks like the one pictured in A, Figure 6-1. The grinder may be converted to 230V single phase power, see sect. 6.3.

Before connecting to power source, be sure switch is in *off* position.

It is recommended that the grinder be connected to a 15-amp circuit with circuit breaker or fuse. If using fuses, they should be time-delay fuses marked "D". **Local codes take precedence over recommendations.**

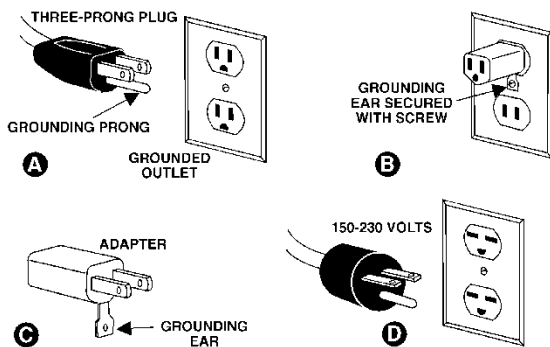

Figure 6-1: plug configurations

### 6.1 Grounding instructions

#### 1. All Grounded, Cord-connected Tools:

This tool must be grounded. In the event of a malfunction or breakdown, grounding provides a path of least resistance for electric current to reduce the risk of electric shock. This tool is equipped with an electric cord having an equipment-grounding conductor and a grounding plug. The plug must be plugged into a matching outlet that is properly installed and grounded in accordance with all local codes and ordinances.

Do not modify the plug provided - if it will not fit the outlet, have the proper outlet installed by a qualified electrician.

Improper connection of the equipment-grounding conductor can result in a risk of electric shock. The conductor with insulation having an outer surface that is green with or without yellow stripes is the equipment-grounding conductor. If repair or replacement of the electric cord or plug is necessary, do not connect the equipment-grounding conductor to a live terminal.

**⚠WARNING** Check with a qualified electrician or service personnel if the grounding instructions are not completely understood, or if in doubt as to whether the tool is properly grounded. Failure to comply may cause serious or fatal injury.

Use only 3-wire extension cords that have 3-prong grounding plugs and 3-pole receptacles that accept the tool's plug.

Repair or replace damaged or worn cord immediately.

2. *Grounded, cord-connected tools intended for use on a supply circuit having a nominal rating less than 150 volts:*

This tool is intended for use on a circuit that has an outlet that looks like the one illustrated in A, Figure 6-1. An adapter, shown in B and C, may be used to connect this plug to a 2-pole receptacle as shown in B if a properly grounded outlet is not available. The temporary adapter should be used only until a properly grounded outlet can be installed by a qualified electrician. *This adapter is not permitted in Canada.* The green-colored rigid ear, lug, and the like, extending from the adapter must be connected to a permanent ground such as a properly grounded outlet box.

3. *Grounded, cord-connected tools intended for use on a supply circuit having a nominal rating between 150 - 250 volts, inclusive:*

This tool is intended for use on a circuit that has an outlet that looks like the one illustrated in D, Figure 6-1. A grounding plug may be installed, that looks like the plug illustrated in D; or the grinder may be "hard-wired" to a panel, provided there is a disconnect for the operator.

Make sure the tool is connected to an outlet having the same configuration as the plug. No adapter is available or should be used with this tool. If the tool must be reconnected for use on a different type of electric circuit, the reconnection should be made by qualified service personnel; and after reconnection, the tool should comply with all local codes and ordinances.

### 6.2 Extension cords

The use of extension cords is discouraged. Try to position equipment near the power source. If an extension cord becomes necessary, use only three-wire extension cords that have three-prong grounding type plugs and three-prong receptacles that accept the tool's plug. Replace or repair damaged or worn cord immediately.

Make sure your extension cord is good condition, and is heavy enough to carry the current your product will draw. An undersized cord will cause a drop in line voltage resulting in loss of power and overheating.

Table 1 shows the correct size to use depending on cord length and nameplate ampere rating. If in doubt, use the next heavier gage. The smaller the gage number (AWG), the heavier the cord.

Ampere Rating		Volts	Total length of cord in feet			
More Than	Not More Than		25	50	100	150
		120	25	50	100	150
		240	50	100	200	300
			AWG			
0	6		18	16	16	14
6	10		18	16	14	12
10	12		16	16	14	12
12	16		14	12	Not Recommended	

Extension Cord Recommendations  
Table 1

### 6.3 Voltage conversion

To change voltage input to 230-volt on the IBG-8VS Grinder, remove existing plug from grinder cable and attach a UL/CSA listed plug designed for 230V power.

## 7.0 Operation

**WARNING** Always use approved safety glasses or face shield while operating grinder. Failure to comply may cause serious injury.

A bench grinder is designed for hand-grinding operations such as sharpening chisels, screwdrivers, drill bits, removing excess metal, and smoothing metal surfaces.

A *Medium Grain Abrasive Grinding Wheel* is suitable for rough grinding where a considerable amount of metal must be removed or when obtaining a smooth finish is not important.

A *Fine Grain Abrasive Grinding Wheel* should be used for sharpening tools or grinding to close size tolerances because it removes metal more gradually for precision grinding and achieves a smoother finish.

### 7.1 Operating controls

Press on/off button on keypad (Figure 7-1) to start or stop. Press any of the numbered buttons to start machine at the designated speed. Press arrow buttons to change rotation speed in 100 RPM increments.

The digital readout displays RPM (revolutions per minute), and will flash briefly during start up and speed adjustments.

The grinder will automatically shut off after 10 minutes of inactivity.

**CAUTION** When OFF button is pushed, the wheels may take a few moments to completely stop.

Note: After extended operation, the grinder housing may be warm to the touch.

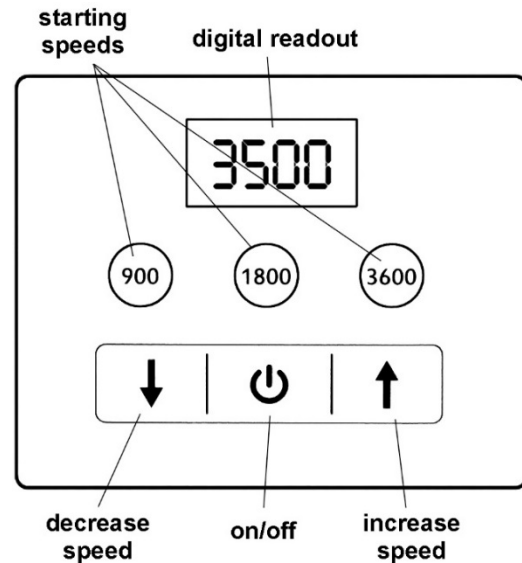

Figure 7-1: keypad

### 7.2 Precautions

1. Before starting the grinder, turn the wheels by hand to verify that they are clear of obstructions and turn freely. The tool rests and spark guards should not touch the wheel.
2. Keep tool rests and spark guards to within 1/16" of the grinding wheel.
3. Turn on the grinder and allow it to reach full running speed before starting to grind.
4. Adjust the eye shields as needed.
5. Keep a steady, moderate pressure on the workpiece and keep it moving at an even pace for smooth grinding. Pressing too hard overheats the motor and prematurely wears the grinding wheels. Note the original bevel angle on the item to be sharpened and try to maintain the same shape. The grinding wheel should rotate into the object being sharpened.
6. If grinding a narrow workpiece, slide it laterally across the width of the wheel. Using the full width of the wheel will help prevent a groove forming at one place on the wheel.
7. Keep a water pot filled with water and dip your work into it regularly to prevent overheating. Overheating can weaken metals. Do not apply water directly to the grinding wheels.
8. Do not use the side of the grinding wheel; this puts dangerous stress on the wheel.

- When the wheel becomes loaded or dull, use an approved grinding wheel dresser and dress the wheel face.

## 8.0 Adjustments

### 8.1 Eye shield tilt adjustment

- Loosen lock knob (A<sub>1</sub>, Figure 8-1).
- Adjust eye shield (A<sub>2</sub>) to the desired tilt angle.
- Tighten lock knob.

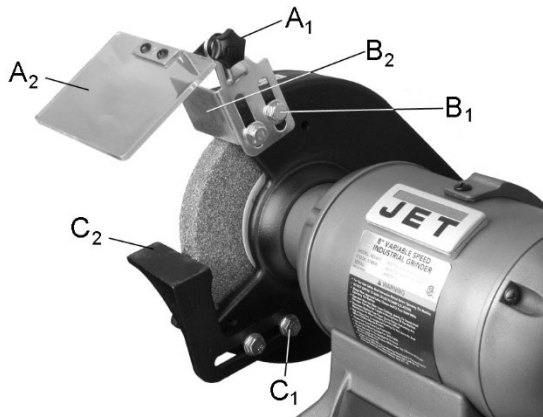

Figure 8-1: eye shield adjustment

### 8.2 Spark guard

As the wheel wears down, the spark guards must be re-adjusted to maintain a 1/16" distance.

Refer to Figure 8-1.

- Loosen two hex cap screws (B<sub>1</sub>) with a 14mm wrench.
- Slide the spark guard (B<sub>2</sub>) to 1/16" distance from the grinding wheel surface.
- Tighten screws (B<sub>1</sub>).

### 8.3 Tool rest

As the wheel wears down, the tool rests must be re-adjusted to maintain a 1/16" distance.

Refer to Figure 8-1.

- Loosen two hex cap screws (C<sub>1</sub>) with a 14mm wrench.
- Slide the tool rest (C<sub>2</sub>) to a distance of 1/16" from the grinding wheel.
- Tighten screws (C<sub>1</sub>).

## 9.0 User-maintenance

For safety, turn the switch to OFF and remove plug from the power source outlet before adjusting and maintaining the bench grinder or buffer. If the power cord is worn, cut or damaged in any way, have it replaced immediately.

### 9.1 Ring test

Before replacing a grinding wheel, perform this simple test on the replacement wheel:

- Loop a piece of string through the grinding wheel hole and suspend the wheel by holding up the string.
- Tap the wheel with a piece of scrap wood or a wooden dowel.
- A good wheel will "ring"; a defective wheel will "thud". Discard any wheel that does not "ring".

An internal defect may not be apparent by visual inspection alone. The ring test may identify an internal crack or void.

### 9.2 Care of grinding wheels

In normal use, grinding wheels may become cracked, grooved, rounded at the edges, chipped, out of true or loaded with foreign material.

Cracked wheels should be replaced IMMEDIATELY. The other conditions can be remedied with a dressing tool. New wheels sometimes require dressing to make them round. See sect. 9.5.

### 9.3 Changing wheels

The JET IBG-8VS bench grinder comes equipped with general purpose grinding wheels. Wheels vary according to types of abrasive, hardness, grit size, and structure. Contact your local distributor for the proper grinding wheel or wire wheel brush for your application.

If you replace a wheel, obtain one with a safe rated speed at least as high as the NO LOAD RPM marked on the grinder's nameplate. Table 2 shows correct dimensions for the replacement wheel.

Model	Wheel Diameter	Maximum Width	Center Hole
IBG-8VS	8"	1"	5/8"

Table 2

Your bench grinder will accept most polishing and buffing wheels available at dealers and hardware stores.

**⚠ WARNING** The use of any other accessory is not recommended and may result in serious injury!

To change a wheel (see Figure 9-1):

- Disconnect grinder from power source.
- Loosen spark guard (B) and tool rest (C) and move them away from the wheel.
- Remove wheel guard using a cross-point or flathead screwdriver.

4. Stabilize wheel by holding opposite wheel firmly, or placing a wood wedge between wheel and tool rest.

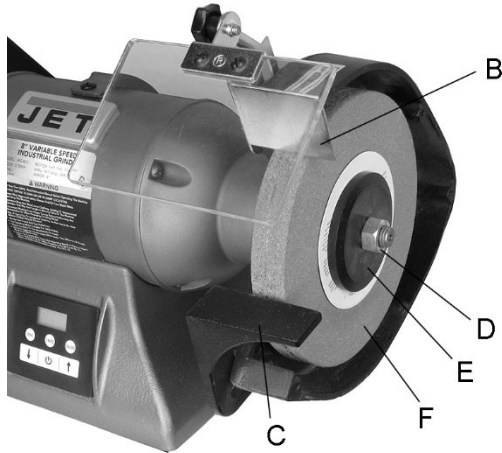

Figure 9-1: wheel replacement

5. Unscrew arbor nut (D) with a wrench.  
**Note:** Turn the nut on the right-hand wheel *counterclockwise* to loosen. Turn the nut on the left-hand wheel *clockwise* to loosen.
6. Remove outer flange (E), wheel (F), and inner flange.
7. Clean flanges. Check the flanges to make sure they are flat. Wheel flanges that are not flat will cause the wheel to wobble.
8. Inspect the new grinding wheel and perform a “ring test”. Do not install a damaged wheel.
9. Install inner flange, wheel (F), outer flange (E) and nut (D) on the shaft. Tighten nut.

**CAUTION** Do not overtighten nut; this may cause the wheel to crack. Maximum safe torque on nut is 20 lbf•ft (270 kgf•cm).

10. Reinstall guard cover. Adjust spark guards and tool rests to 1/16" clearance from wheel.

## 9.4 Wheel balancing

With the grinder **unplugged from the power source**, and arbor nuts snugged down, rotate wheels by hand and observe their motion.

A grinding wheel has proper balance when:

1. The wheel’s outside face spins true and round; that is, its circumference rotates concentric to the arbor.
2. There is no side-to-side wobble.

The operator who takes time to patiently perform needed adjustments will be rewarded by wheels running true, and accurate grinding of work pieces.

### 9.4.1 Adjusting concentricity

If the outside face is not rotating concentric to arbor, try shifting the wheel closer to arbor centerline before tightening the nut.

Another method of achieving concentricity is the use of a wheel dresser. “Dressing” is the removal of the current layer of abrasive to expose a fresh surface. A wheel dresser is also used to “true” a wheel; that is, to make the grinding surface parallel to the tool rest, so the entire wheel face presents an even surface to the work piece. Proper use of a wheel dresser will eliminate high spots and result in concentric rotation about the arbor, as well as minimize vibration. See sect. 9.5.

### 9.4.2 Correcting side-to-side wobble

The IBG-8VS Grinder has large, machined flanges, making wobble unlikely if a good quality grinding wheel is used. Should a wheel exhibit need for adjustment:

1. Loosen nut and rotate the outer flange a little. Snug the nut and spin the wheel by hand to check.
2. If wobble still exists, continue repeating step 1, rotating outer flange incrementally in the same direction. See Figure 9-2. Make sure to keep the wheel in the same position each time.



Figure 9-2: wheel balancing

3. If complete rotation of outer flange has proved ineffective, remove nut, outer flange, and wheel (keep wheel in same orientation by placing a pencil mark on it somewhere for reference). Then rotate inner flange about 90° and repeat the above steps for the outer flange.
4. Continue this combination of flange movements until the wobble is eliminated.

If required, a shim made of paper or card stock may be placed between flange and wheel side.

**NOTE:** Very slight wobble may still exist at spin-up and spin-down, but will not affect normal speed operation.

## 9.5 Dressing the wheels

Below is a general procedure for dressing a grinding wheel.

**⚠WARNING** Use safety glasses or face shield during dressing operations.

1. Back off the tool rest enough to allow the dresser to hook over its inside edge (Figure 9-3). Tighten tool rest in position.
2. Turn on grinder and allow it to reach operating speed.
3. Set the wheel dresser on the rest and bring it into contact with the wheel by raising its handle. Hold the dresser firmly.

**Note:** If sparks appear, increase the pressure of the dresser discs against the wheel.

4. Move the dresser evenly left and right across the wheel face until the wheel looks clean and is square to the tool rest.
5. Remove the dresser, and adjust the tool rest to 1/16" away from the newly dressed wheel.

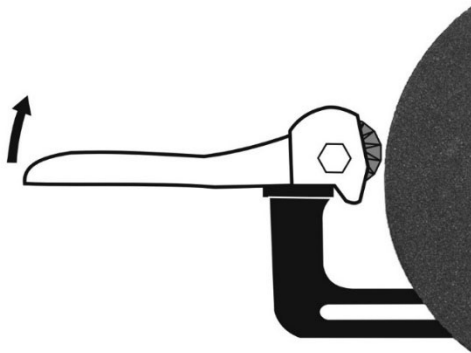

Figure 9-3: wheel dressing

## 9.6 Wire wheel brushes

Wire brushing provides a fast way to remove rust scale, burrs, and paint from metal. Use coarse wire brushes for hard cleaning jobs. Use fine wire brushes for polishing and finish work. When the brush tips become dull, reverse the brush on the grinder.

## 9.7 Cleaning

**⚠CAUTION** Metal shavings may still be hot from recent grinding operations. Make sure shavings and debris are cold before cleaning the grinder.

Brush all shavings from the motor housing, tool rests, and wheel guards. Check grinding wheels for cracks and chips. Replace if damaged.

**⚠CAUTION** Avoid use of the following cleaning chemicals or solvents: gasoline, carbon tetrachloride, chlorinated solvents, ammonia and household detergents containing ammonia.

## 9.8 Lubrication

All motor bearings are permanently lubricated and sealed at the factory and require no additional lubrication.

## 9.9 Additional servicing

Any additional servicing on the grinder should be performed by an authorized service representative.

# 10.0 Troubleshooting IBG-8VS Bench Grinder

## 10.1 General electrical and mechanical problems

Table 3

Symptom	Possible Cause	Correction *
Motor will not start.	Not connected to power source.	Verify that plug is properly inserted into receptacle.
	Motor cord cut or abraded.	Replace with new cord.
	Wheels cannot rotate because of obstruction.	Unplug and turn wheel by hand to ensure free movement. Restart.
	Plug on cord is faulty.	Replace with new plug.
	Low line voltage.	Check power line for proper voltage.
	Fuse blown or circuit breaker open.	Re-set. May be too many machines on one line.
	Faulty switch.	Replace switch.
	Open circuit in motor or loose connection.	Inspect all lead connections on motor for loose or open connections.
	Motor faulty, or inverter PCB fault.	Contact JET technical service.
Motor will not start; fuses blow or circuit breakers trip.	Too many electrical machines running on same circuit.	Turn off other machines and try again.
	Incorrect fuse.	Use time-delay fuse, or go to circuit with higher rated fuse or breaker.
	Wheels cannot rotate because of obstruction.	Unplug and turn grinding wheel by hand to ensure free movement. Clear any obstructions and restart.
	Undersized extension cord.	Use correct size extension cord.
	Short circuit in line cord or plug.	Inspect cord or plug for damaged insulation and shorted wires.
	Short circuit in motor or loose connections.	Inspect all connections on motor for loose or shorted terminals or worn insulation.
Motor fails to develop full power.	Low line voltage.	Check power line for proper voltage.
	Faulty motor or capacitor	Contact JET technical service.
Motor overheats.	Motor overloaded.	Reduce pressure against wheel. Make sure grit size is appropriate for the job.
Motor stalls, resulting in blown fuses or tripped circuit.	Motor overloaded.	Reduce load on motor; do not press so hard.
	Capacitor failure.	Contact JET technical service.
	Short circuit in motor or loose connections.	Inspect connections on motor for loose or shorted terminals or worn insulation.
	Low voltage.	Correct the low voltage conditions.
	Incorrect fuses or circuit breakers in power line.	Install correct fuses or breakers.

Symptom	Possible Cause	Correction *
Motor slows.	Motor overloaded.	Reduce load to motor; do not press so hard.
	Low line voltage.	Check power line for proper voltage.
	Loose connections.	Inspect connections.
Frequent fuse or circuit breaker failure.	Motor overload.	Reduce load to motor; do not press so hard.
	Electrical circuit overload; too many electrical machines running on same circuit.	Turn off other machines and try again.
	Incorrect fuse or circuit breaker	Have electrician upgrade service to outlet.
Excessive vibration.	Wheel(s) out of balance; wobbling or not rotating concentric to arbor.	Dress wheel or replace it. Adjust wobble by rotating flange as needed.
	Improper mounting.	Secure machine firmly to bench or stand.

## 10.2 Digital readout error codes

Table 4

Message	Possible Cause	Correction *
OCL	Internal electronic overload has been tripped.	Do not overload motor; reduce pressure of workpiece against wheels.
OH	IGBT protection activated.	Inspect wire connections to U/V/W for possible short circuits. Verify that motor rating corresponds to AC motor drive output power.
OE	Excessive input voltage (exceeds AC driver limits).	Use correct voltage.
LE1	Low voltage; AC motor driver detects that DC bus voltage has fallen below minimum threshold	Make sure input voltage falls within range of AC motor input voltage range. Check for abnormal load in motor.
LP1	Low input voltage (below AC driver limits)	Use correct voltage.

\* **WARNING:** Some corrections may required a qualified electrician.



# 11.0 Optional accessories

These accessory items, purchased separately, are available for your JET bench grinder or buffer. Contact your dealer to order, or call JET at the phone number on the cover.



**578172**  
IBG Stand



**578173**  
Deluxe IBG Stand



**578100**  
Flexible 3W LED Lamp  
(includes two 1/4 x 3/8 mounting screws)

The following accessories are for using Grinder with the JET #414800 (JDCS-505) Dust Collection Stand:

- 414825** Reducer, 3 in. to 2.5 in.
- 414811** 0.6M Hose, Heat Resistant,  $\varnothing$ 2.5 x 24.4 in.

# 12.0 Replacement Parts

Replacement parts are listed on the following pages. To order parts or reach our service department, call 1-800-274-6848 Monday through Friday, 8:00 a.m. to 5:00 p.m. CST. Having the Model Number and Serial Number of your machine available when you call will allow us to serve you quickly and accurately.

Non-proprietary parts, such as fasteners, can be found at local hardware stores, or may be ordered from JET. Some parts are shown for reference only, and may not be available individually.

# 12.1.1 IBG-8VS Variable Speed Grinder – Exploded View

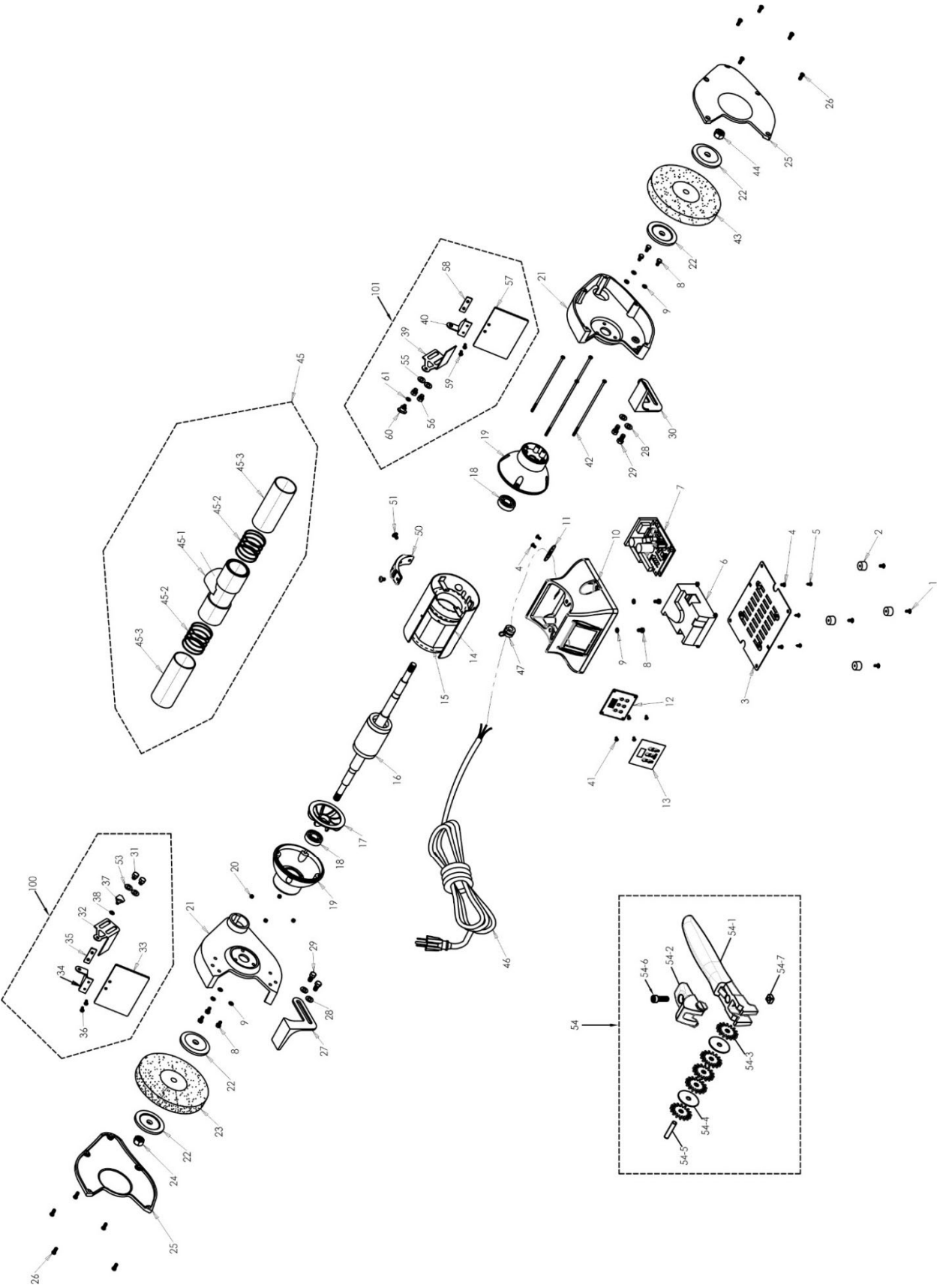

## 12.1.2 IBG-8VS Variable Speed Grinder – Parts List

Index No.	Part No.	Description	Size	Qty
1	IBG8-01	Truss Head Screw	3/16"-24 x 1/4"	4
2	IBG8-02	Rubber Pad		4
3	IBG8-03	Base Plate		1
4	IBG8-04	Truss Head Screw	3/16"-24 x 3/8"	4
5	F011289	Truss Head Phillips Tap Screw	#8x1/2"	4
6	IBG8VS-06	Electrical Box		1
7	IBG8VS-07	Inverter PCB		1
8	TS-0050021	Hex Cap Screw	1/4"-20 x 5/8"	8
9	TS-0720071	Lock Washer	1/4"	8
10	IBG8VS-10	Base		1
11	IBG8-11	Cord Plate		1
12	IBG8VS-12	Control Panel w/ Digital Readout (includes #13)		1
13	IBG8VS-13	Panel Decal		1
14	IBG8VS-14	Motor Housing		1
15	IBG8VS-15	Stator		1
16	IBG8VS-16	Rotor		1
17	IBG8-17	Motor Fan		1
18	BB-6204ZZ	Ball Bearing	6204ZZ	2
19	IBG8-19	End Bell		2
20	TS-1540031	Hex Nut	M5	4
21	IBG8-21	Wheel Guard		2
22	IBG8-22	Wheel Flange		4
23	IBG8-23	Grinding Wheel	#36 Grit, 8" Dia	1
24	IBG8-24	Hex Nut (Left Hand Thread)	5/8"-11UNC	1
25	IBG8-25	Wheel Cover		2
26	IBG8-26	Truss Head Screw	1/4"-20 x 3/4"	10
27	IBG8-27	Tool Rest-Left		1
28	TS-0680041	Flat Washer	3/8"	4
29	IBG8-29	Hex Cap Screw	3/8"-16 x 3/4"	4
30	IBG8-30	Tool Rest-Right		1
31	TS-0060011	Hex Cap Screw	3/8"-16 x 1/2"	4
32	IBG8-32	Spark Guard – Left		1
33	IBG8-33	Eye Shield		1
34	IBG8-34	Eye Shield Bracket -Left		1
35	IBG8-35	Eye Shield Plate		1
36	IBG8-36	Truss Head Screw	3/16"-24 x 1/2"	2
37	IBG8-37	Knob		1
38	TS-0680021	Flat Washer	1/4"	1
39	IBG8-39	Spark Guard – Right		1
40	IBG8-40	Eye Shield Bracket – Right		1
41	TS-2284082	Pan Head Screw	M4 x 8	4
42	IBG8-42	Screw	M5 x 0.8 x 205	4
43	IBG8-43	Grinder Wheel	#60 Grit, 8" Dia	1
44	IBG8-44	Hex Nut (Right Hand Thread)	5/8"-11UNC	1
45	IBG8-45B	Dust Port Assembly		1
45-1	IBG8-45-1	T Fitting		1
45-2	IBG8-45-2	Spring		2
45-3	IBG8-45-3	Connector Sleeve		2
46	IBG8-46	Power Cord with 15A Plug	16AWG x 3C SJT	1
47	IBG8-47	Strain Relief		1
50	IBG8-50	Lamp Fixed Bracket		1
51	F000296	Flat Hd Phillips Machine Screw	1/4"-20 x 3/8"	2
53	TS-0680041	Flat Washer	3/8"	2
54	IBG8-54	Dresser Assembly	Dia. 1-1/4	1
54-1	IBG8-54-1	Body		1
54-2	IBG8-54-2	Hood		1
54-3	IBG8-54-3	Cutter		4
54-4	IBG8-54-4	Cutter Washer		2
54-5	IBG8-54-5	Pin	6mm	1
54-6	TS-1503051	Socket Head Cap Screw	M6 x 20	1

<b>Index No</b>	<b>Part No</b>	<b>Description</b>	<b>Size</b>	<b>Qty</b>
54-7	IBG8-54-7	Square Nut	M6	1
55	TS-0680041	Flat Washer	3/8"	2
56	TS-0060011	Hex Cap Screw	3/8"-16 x 1/2"	2
57	IBG8-33	Eye Shield		1
58	IBG8-35	Eye Shield Plate		1
59	IBG8-36	Truss Head Screw	3/16"-24 x 1/2"	2
60	IBG8-37	Knob		1
61	TS-0680021	Flat Washer	1/4"	1
100	IBG8-100	Eye Shield Assembly – Left (includes 31-38,53)		1
101	IBG8-101	Eye Shield Assembly – Right (includes 39,40,55-61)		1
	JET-92	JET Logo (not shown)	92x38mm	1
	LM000277	ID/Warning Label, IBG-8VS (not shown)		1

**12.2.1 IBG-Stand Assembly (OPTIONAL) – Exploded View**

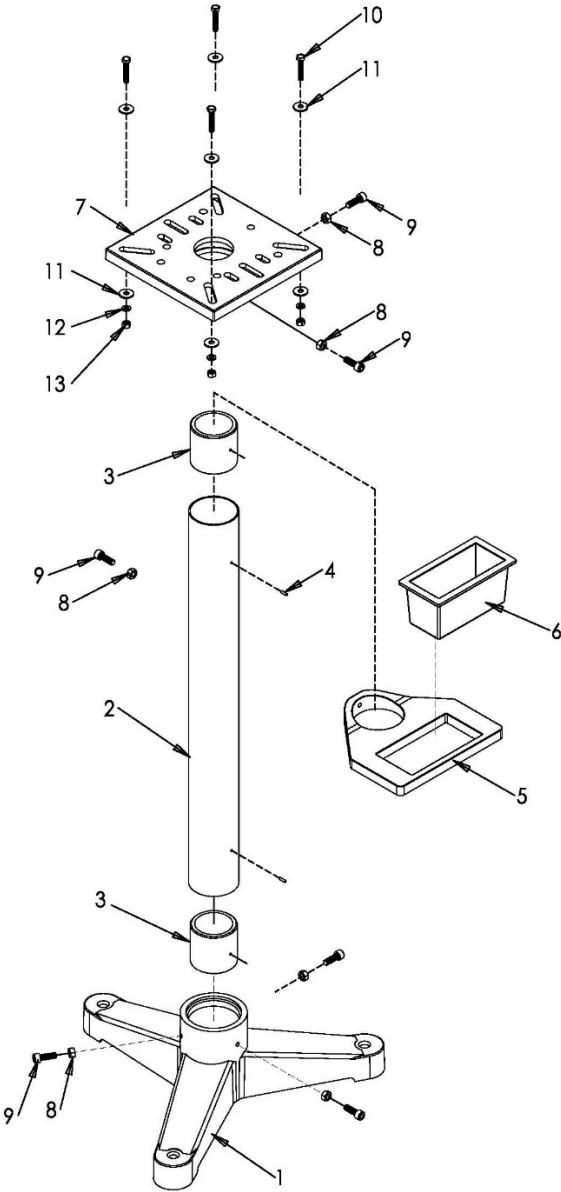

**12.2.2 IBG-Stand Assembly (OPTIONAL) – Parts List**

Index No.	Part No.	Description	Size	Qty
	578172	IBG-Stand for Bench Grinders (#1 thru 13)		1
1	IBGS-01	Base		1
2	IBGS-02	Post (includes #3 and #4)		1
3	IBGS-03	Insert Ring		2
4	IBGS-04	Pin	Ø4 x 14	2
5	IBGS-05	Water Pot Holder		1
6	IBGS-06	Water Pot		1
7	IBGS-07	Platform		1
8	TS-1540071	Hex Nut	M10	6
9	TS-1505041	Socket Head Cap Screw	M10 X 30	6
10	TS-1490071	Hex Cap Screw	M8 x 40	4
11	TS-1550061	Flat Washer	M8	8
12	TS-2361081	Lock Washer	M8	4
13	TS-1540061	Hex Nut	M8	4

### 12.3.1 DBG-Stand Assembly (OPTIONAL) – Exploded View

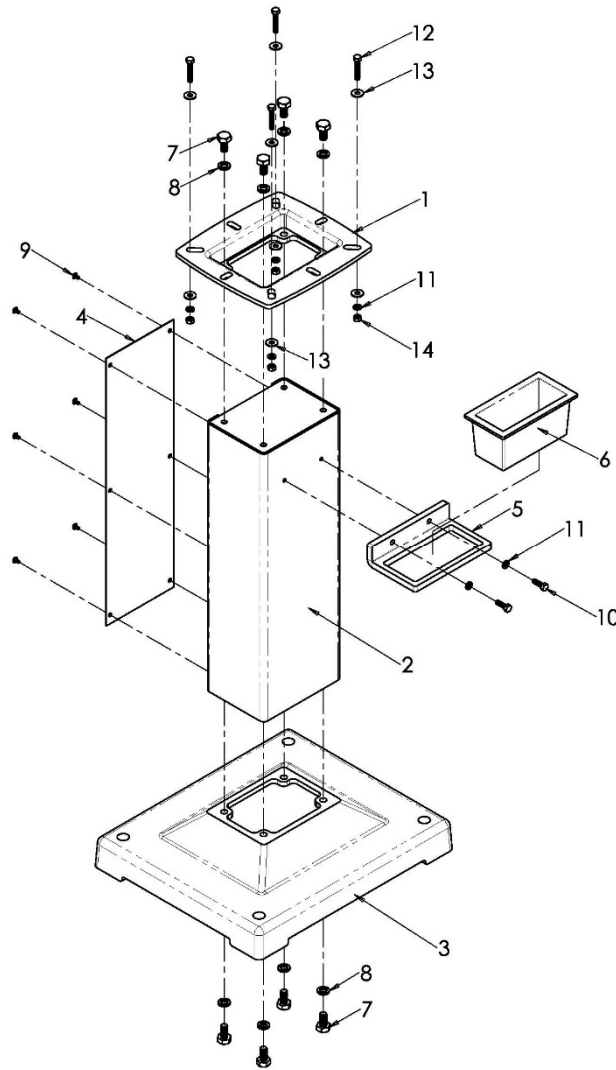

### 12.3.2 DBG-Stand Assembly (OPTIONAL) – Parts List

Index No.	Part No.	Description	Size	Qty
.....	578173	DBG-Stand for Bench Grinders (#1 thru 14)	.....	1
1	DBGS-01	Platform	.....	1
2	DBGS-02	Stamped Stand Front	.....	1
3	DBGS-03	Base	.....	1
4	DBGS-04	Stamped Stand Cover	.....	1
5	DBGS-05	Water Pot Holder	.....	1
6	IBGS-06	Water Pot	.....	1
7	TS-0070011	Hex Cap Screw	1/2"-13 x 1"	8
8	TS-0720111	Lock Washer	1/2"	8
9	TS-081F032	Pan Head Machine Screw	1/4"-20 x 3/8"	6
10	TS-0051051	Hex Cap Screw	5/16"-18 x 1"	2
11	TS-0720081	Lock Washer	5/16"	6
12	TS-1490071	Hex Cap Screw	M8 x 40	4
13	TS-2361081	Lock Washer	M8	8
14	TS-2311081	Hex Nut	M8	4

# 13.0 Electrical Connections – IBG-8VS Grinder

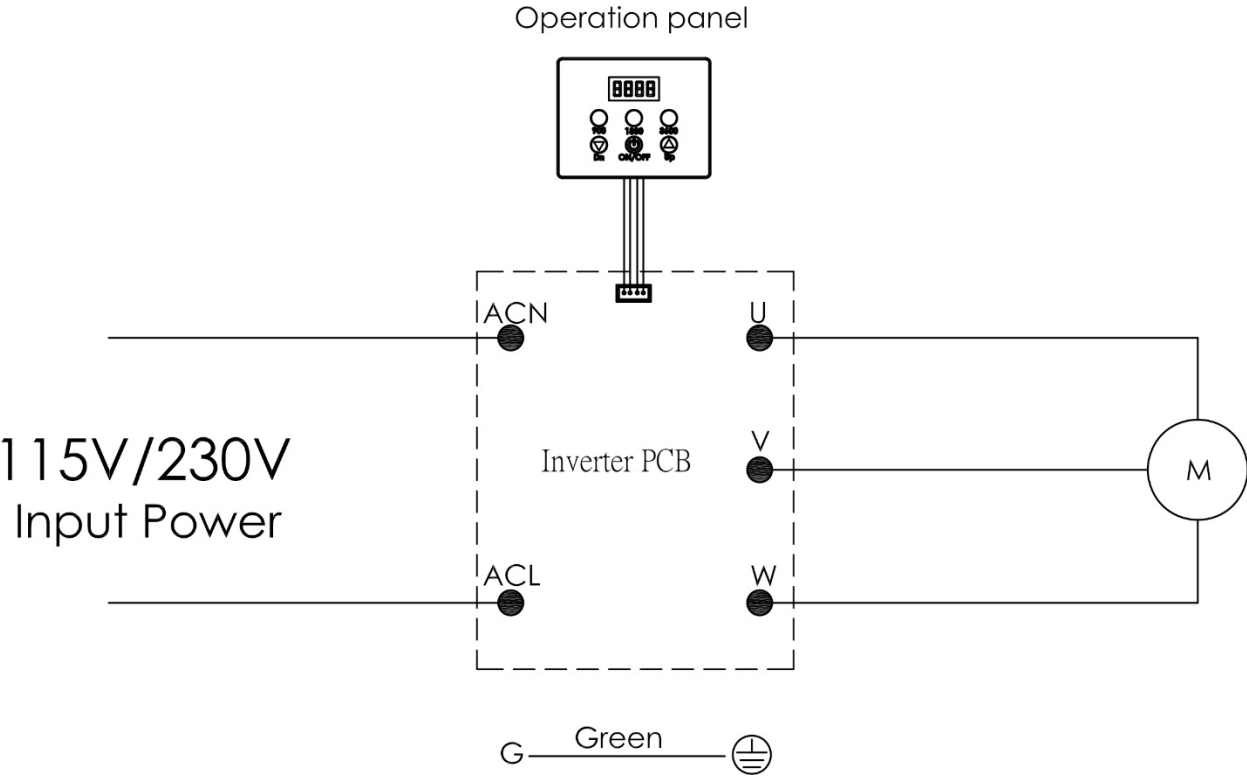

# 14.0 Warranty and Service

JET® warrants every product it sells against manufacturers' defects. If one of our tools needs service or repair, please contact Technical Service by calling 1-800-274-6846, 8AM to 5PM CST, Monday through Friday.

### Warranty Period

The general warranty lasts for the time period specified in the literature included with your product or on the official JET branded website.

- JET products carry a limited warranty which varies in duration based upon the product. (See chart below)
- Accessories carry a limited warranty of one year from the date of receipt.
- Consumable items are defined as expendable parts or accessories expected to become inoperable within a reasonable amount of use and are covered by a 90 day limited warranty against manufacturer's defects.

### Who is Covered

This warranty covers only the initial purchaser of the product from the date of delivery.

### What is Covered

This warranty covers any defects in workmanship or materials subject to the limitations stated below. This warranty does not cover failures due directly or indirectly to misuse, abuse, negligence or accidents, normal wear-and-tear, improper repair, alterations or lack of maintenance. JET woodworking machinery is designed to be used with Wood. Use of these machines in the processing of metal, plastics, or other materials outside recommended guidelines may void the warranty. The exceptions are acrylics and other natural items that are made specifically for wood turning.

### Warranty Limitations

Woodworking products with a Five Year Warranty that are used for commercial or industrial purposes default to a Two Year Warranty. Please contact Technical Service at 1-800-274-6846 for further clarification.

### How to Get Technical Support

Please contact Technical Service by calling 1-800-274-6846. **Please note that you will be asked to provide proof of initial purchase when calling.** If a product requires further inspection, the Technical Service representative will explain and assist with any additional action needed. JET has Authorized Service Centers located throughout the United States. For the name of an Authorized Service Center in your area call 1-800-274-6846 or use the Service Center Locator on the JET website.

### More Information

JET is constantly adding new products. For complete, up-to-date product information, check with your local distributor or visit the JET website.

### How State Law Applies

This warranty gives you specific legal rights, subject to applicable state law.

### Limitations on This Warranty

JET LIMITS ALL IMPLIED WARRANTIES TO THE PERIOD OF THE LIMITED WARRANTY FOR EACH PRODUCT. EXCEPT AS STATED HEREIN, ANY IMPLIED WARRANTIES OF MERCHANTABILITY AND FITNESS FOR A PARTICULAR PURPOSE ARE EXCLUDED. SOME STATES DO NOT ALLOW LIMITATIONS ON HOW LONG AN IMPLIED WARRANTY LASTS, SO THE ABOVE LIMITATION MAY NOT APPLY TO YOU. JET SHALL IN NO EVENT BE LIABLE FOR DEATH, INJURIES TO PERSONS OR PROPERTY, OR FOR INCIDENTAL, CONTINGENT, SPECIAL, OR CONSEQUENTIAL DAMAGES ARISING FROM THE USE OF OUR PRODUCTS. SOME STATES DO NOT ALLOW THE EXCLUSION OR LIMITATION OF INCIDENTAL OR CONSEQUENTIAL DAMAGES, SO THE ABOVE LIMITATION OR EXCLUSION MAY NOT APPLY TO YOU.

JET sells through distributors only. The specifications listed in JET printed materials and on official JET website are given as general information and are not binding. JET reserves the right to effect at any time, without prior notice, those alterations to parts, fittings, and accessory equipment which they may deem necessary for any reason whatsoever. JET® branded products are not sold in Canada by JPW Industries, Inc.

### Product Listing with Warranty Period

90 Days – Parts; Consumable items
1 Year – Motors; Machine Accessories
2 Year – Metalworking Machinery; Electric Hoists, Electric Hoist Accessories; Woodworking Machinery used for industrial or commercial purposes
5 Year – Woodworking Machinery
Limited Lifetime – JET Parallel clamps; VOLT Series Electric Hoists; Manual Hoists; Manual Hoist Accessories; Shop Tools; Warehouse & Dock products; Hand Tools; Air Tools

NOTE: JET is a division of JPW Industries, Inc. References in this document to JET also apply to JPW Industries, Inc., or any of its successors in interest to the JET brand.