



Multi Extreme

INCH

METRIC

Face Mill EXM-HF Type

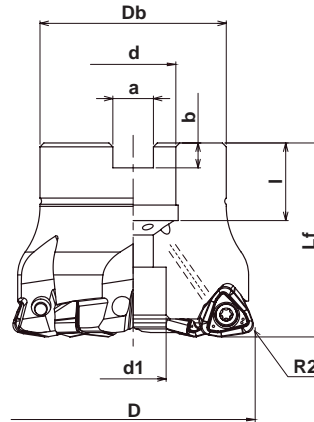

G-Body

Specifications - Inch

CATALOG NUMBER	STK	DIMENSIONS								INSERT	Q	PARTS	
		D	Lf	Db	d	d1	a	b	l			Screw	Wrench
EXM-4200R-HF-075	•	2.00	2.00	1.77	.750	.590	.319	.197	.750	WNMU070620ZER-PM	4	TSW-410H	A-15T
EXM-5200R-HF-075	•	2.00	2.00	1.77	.750	.590	.319	.197	5				
EXM-6250R-HF-100	•	2.50	2.00	1.89	1.00	.787	.374	.236	.945		6		
EXM-7300R-HF-100	•	3.00	2.00	2.85	1.00	.787	.374	.236	.945		7		
EXM-7300R-HF-125	•	3.00	2.50	2.85	1.25	1.024	.500	.315	1.26		7		
EXM-7400R-HF-150	•	4.00	2.25	3.78	1.50	1.189	.636	.394	1.00		7		

Note: All cutters are supplied without inserts or wrenches.

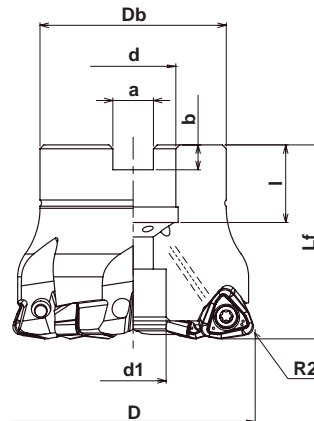

G-Body

Specifications - Metric

CATALOG NUMBER	STK	DIMENSIONS								INSERT	Q	PARTS	
		D	Lf	Db	d	d1	a	b	l			Screw	Wrench
EXM-5050R-HF-22	•	50	50	40	22	16.5	10.4	6.3	20	WNMU070620ZER-PM	5	TSW-410H	A-15T
EXM-5052R-HF-22	◦	52	50	40	22	16.5	10.4	6.3	20		5		
EXM-6063R-HF-22	•	63	50	48	22	17	10.4	6.3	20		6		
EXM-7080R-HF	•	80	70	65	31.75	26	12.7	8	32		7		
EXM-7080R-HF-27	•	80	55	65	27	20	12.4	7	22		7		

Note: All cutters are supplied without inserts or wrenches.



INCH

METRIC

Multi Extreme

Face Mill EXM-SM Type

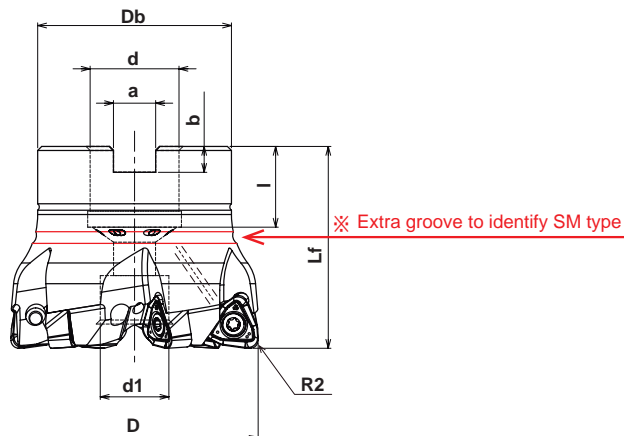

Specifications - Inch

CATALOG NUMBER	STK	DIMENSIONS								INSERT	Q	PARTS	
		D	Lf	Db	d	d1	a	b	l			Screw	Wrench
EXM-5200R-SM-075	•	2.00	2.00	1.77	.750	.590	.319	.197	.750	WNMU070620ZER-PM	5	TSW-410H	A-15T
EXM-6250R-SM-100	•	2.50	2.00	1.89	1.00	.787	.374	.236	.945		6		
EXM-7300R-SM-100	•	3.00	2.00	2.85	1.00	.787	.374	.236	.945		7		
EXM-7300R-SM-125	•	3.00	2.50	2.85	1.25	1.024	.500	.315	1.26		7		

Note: All cutters are supplied without inserts or wrenches.

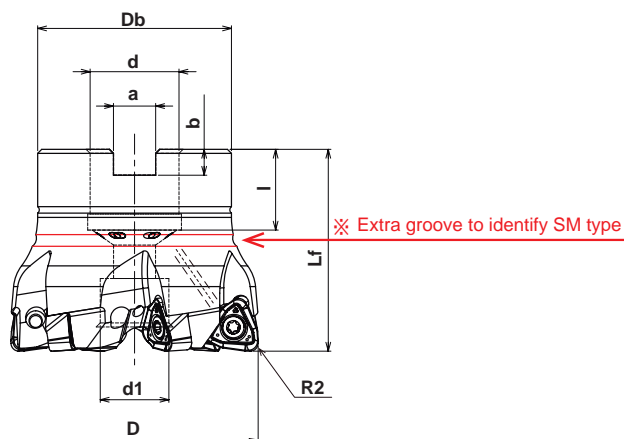

Specifications - Metric

CATALOG NUMBER	STK	DIMENSIONS								INSERT	Q	PARTS	
		D	Lf	Db	d	d1	a	b	l			Screw	Wrench
EXM-5050R-SM-22	•	50	50	40	22	16.5	10.4	6.3	20	WNMU070620ZER-PM	5	TSW-410H	A-15T
EXM-5052R-SM-22	◦	52	50	40	22	16.5	10.4	6.3	20		5		
EXM-6063R-SM-22	•	63	50	48	22	17	10.4	6.3	20		6		

◦ - longer delivery may apply.

Note: All cutters are supplied without inserts or wrenches.