

T-Slot Nuts

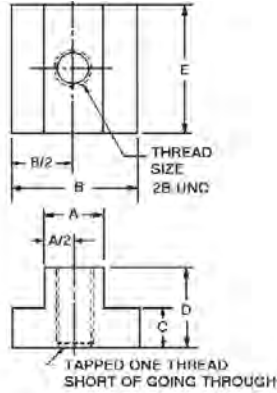

- Material: Low Carbon Steel, 303 Stainless
- Finish: Black Oxide
- Threads: 2B-UNC (Inch); Class 6h (Metric)
- Heat Treat: Case Hardened
- Available in metric sizes. See below.

Part Number	Thread	T-slot Width A	B	C	D	E	Wt. (lbs) 10 Pcs.
*43302**	3/8-16	7/16	11/16	7/32	1/2	7/8	0.50
*43303**	3/8-16	1/2	7/8	9/32	1/2	7/8	.070
43301	3/8-16	9/16	7/8	1/4	1/2	7/8	0.70
*43305**	1/2-13	9/16	7/8	11/32	5/8	1 1/8	1.20
*43306	1/2-13	5/8	1	11/32	5/8	1 1/8	1.50
*43304	1/2-13	11/16	1 1/8	7/16	3/4	1 1/4	2.10
*43308**	5/8-11	11/16	1 1/8	7/16	3/4	1 1/4	1.14
*43309	5/8-11	3/4	1 1/4	15/32	3/4	1 1/4	1.60
*43307	5/8-11	13/16	1 1/4	9/16	1	1 1/2	3.11
*43311**	3/4-10	13/16	1 1/4	9/16	1	1 1/2	3.60
43312	3/4-10	7/8	1 1/2	9/16	1	1 1/2	4.10
*43310	3/4-10	1 1/16	1 5/8	1 1/16	1 1/4	2	7.20
43313**	7/8-9	1	1 5/8	5/8	1 1/4	2	7.30
43314	7/8-9	1 1/16	1 3/4	5/8	1 1/4	2	8.00

Jergens Feature:

Jergens Table-Saver design provides a safety-stop feature to prevent turning stud into tableways.

*Conforms to TCMA.
**Not Hardened

Metric

Part Number	Thread	T-slot Width A	B	C	D	E	Material
43372	M10 x 1.5	12	19	7	13	25	Steel
43373	M10 x 1.5	14	22	9	16	29	Steel
43374	M10 x 1.5	16	25	9	16	29	Steel
43375	M12 x 1.75	14	22	9	16	29	Steel
43376	M12 x 1.75	16	25	9	16	29	Steel
43377	M12 x 1.75	18	29	11	19	32	Steel
43378	M16 x 2.0	18	29	11	19	32	Steel
43379	M16 x 2.0	20	32	14	25	38	Steel
43380	M16 x 2.0	22	35	14	25	38	Steel
43381	M20 x 2.5	22	35	14	25	38	Steel
43382	M20 x 2.5	24	38	16	25	44	Steel
43383	M20 x 2.5	28	41	18	29	51	Steel

Stainless Steel

Part Number	Thread	T-slot Width A	B	C	D	E
43402	3/8-16	7/16	3/4	7/32	1/2	1
43403	3/8-16	1/2	7/8	1/4	5/8	7/8
43405	1/2-13	9/16	7/8	5/16	3/4	1 1/4
43406	1/2-13	5/8	1	3/8	3/4	1 1/4
43408	5/8-11	11/16	1 1/4	15/32	1	1 1/2
43409	5/8-11	3/4	1 1/4	17/32	1 1/4	1 1/2
43411	3/4-10	13/16	1 1/2	9/16	1	1 3/4
43410	3/4-10	1 1/16	1 5/8	9/16	1	1 3/4

Kwik-Turn T-Slot Nuts

- 1/4 turn design allows the Kwik-Turn to be installed from the top of the T-Slot, in order to avoid uninstallation of set-ups when additional nuts and studs are required
- Material: Low Carbon Steel,
- Finish: Black Oxide
- Threads: 2B-UNC (Inch)
- Heat Treat: Case Hardened

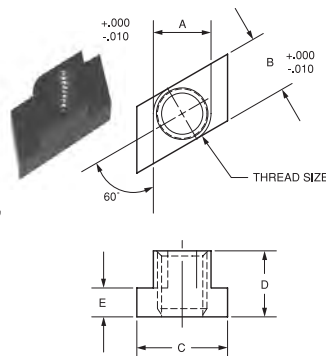

Part Number	Thread	T-Slot	A	B	C	D	E	Wt. (lbs) 10 Pcs.
43332**	3/8-16	7/16	.432	.432	11/16	1/2	7/32	0.27
43333	3/8-16	1/2	.495	.495	7/8	1/2	9/32	0.45
43334**	1/2-13	11/16	.683	.683	1-1/8	3/4	7/16	0.58
43335	1/2-13	9/16	.562	.562	7/8	5/8	11/32	0.79
43336	1/2-13	5/8	.620	.620	1	5/8	11/32	1.26
43338**	5/8-11	11/16	.683	.683	1-1/8	3/4	7/16	1.08
43339	5/8-11	3/4	.745	.745	1-1/4	3/4	15/32	1.44
43345	3/4-10	1	.995	.995	1-5/8	1	5/8	3.50

Jergens Feature:

Jergens Table-Saver design provides a safety-stop feature to prevent turning stud into tableways.

**Not Hardened