



SIC-EVO

INCH

METRIC

FACE MILL SSV type

With coolant hole

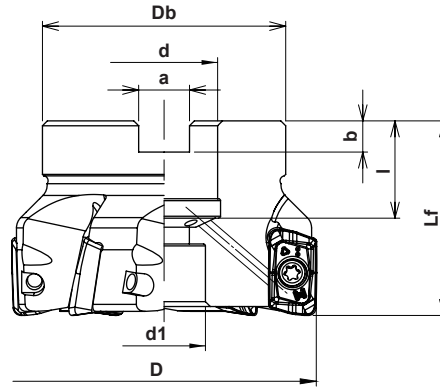

Specifications - Inch

CATALOG NUMBER	STK	DIMENSIONS								Q	INSERT	PARTS
		D	Lf	Db	d	d1	a	b	l			Screw & Wrench
SSV-4200R-075	•	2.0	1.57	1.85	.750	.590	.318	.196	.750	4	ZOMT1605**ZER-PM ZOET160508ZER-PM ZOET160508ZFR-NL	DSW-4075H T-15
SSV-5200R-075	•	2.0	1.57	1.85	.750	.590	.318	.196	.750	5		
SSV-6250R-100	•	2.5	1.75	1.96	1.00	.787	.374	.236	.750	6		
SSV-7300R-100	•	3.0	1.75	2.21	1.00	.787	.374	.236	.750	7		
SSV-8400R-150	•	4.0	2.25	3.78	1.50	1.02	.626	.394	1.00	8		

Note: All cutters supplied without inserts, wrench, & moly.

Specifications - Metric

CATALOG NUMBER	STK	DIMENSIONS								Q	ARBOR BOLT	INSERT	PARTS
		D	Lf	Db	d	d1	a	b	l				Screw & Wrench
SSV-4040R-16	⊙	40	40	35	16	15	8.4	5.6	18	4	M8	ZOMT1605**ZER-PM ZOET160508ZER-PM ZOET160508ZFR-NL	DSW-4075H T-15
SSV-5050R-22	⊙	50	40	47	22	16	10.4	6.3	20	5	M10		
SSV-6063R-22	⊙	63	40	50	22	17	10.4	6.3	20	6	M10		
SSV-6063R-27	⊙	63	50	60	27	20	12.4	7	22	6	M12x1.75x30*		
SSV-7080R	⊙	80	50	60	25.4	20	9.5	6	24	7	M12x1.75x30*		
SSV-7080R-27	⊙	80	50	60	27	20	12.4	7	22	7	M12x1.75x30*		
SSV-8100R	⊙	100	63	85	31.75	26	12.7	8	32	8	M16x2x40*		
SSV-8100R-32	⊙	100	50	85	32	26	14.4	8	25	8	M16x2x30*		
SSV-8125R	⊙	125	70	100	38.1	32	15.9	10	38	8	M20x2.5x40*		
SSV-8125R-40	⊙	125	63	100	40	32	16.4	9	32	8	M20x2.5x40*		

⊙ - delivery may be longer

Note: All cutters supplied without inserts, wrench, & moly.

NOTE: Arbor bolt included on cutters marked with * under arbor bolt column. All other cutters use bolt supplied with arbor.